



INSTRUCTION BOOK FOR
Large Cosmopolitan® Electrol®



Important Safety Instructions

When using your video equipment, basic safety precautions should always be followed, including the following:

1. Read and understand all instructions before using.
2. Position the cord so that it will not be tripped over, pulled, or contact hot surfaces.
3. If an extension cord is necessary, a cord with a current rating at least equal to that of the appliance should be used. Cords rated for less amperage than the appliance may overheat.
4. To reduce the risk of electric shock, do not disassemble this appliance. Contact an authorized service dealer when repair work is required. Incorrect reassembly can cause electric shock when the appliance is used subsequently.
5. The use of an accessory attachment not recommended by the manufacturer may cause a risk of fire, electric shock, or injury to persons.

Save These Instructions

Pre-Installation

1. Carefully unpack screen and remove outer wrapping from case.
2. Remove the black tape and rubber bands from the slat bar after the case has been installed.

Ironing Board

The Large Cosmopolitan Electrol includes an ironing board to flatten the fabric (long strip attached). The ironing board is part of the screen case. Do not remove. Contact Da-Lite if the ironing board is in need of adjustment. (Fig. 1).

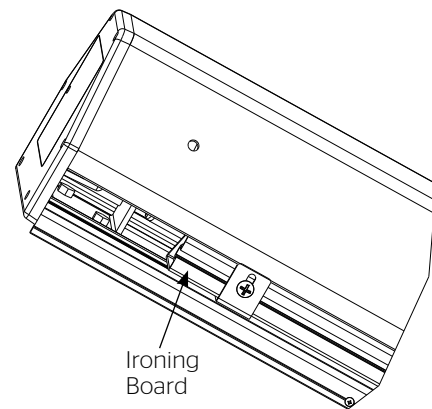

Figure 1

Installation

Carefully unpack screen and remove outer wrapping from case.

Remove the black tape and rubber bands from the slat bar after the case has been installed.

The Large Cosmopolitan Electrol comes with brackets to allow for wall mount or ceiling mount installations. Procedures for each method are as follows:

Wall Mount

1. The wall mount bracket should be fastened to wall studs or some reinforcement within the wall. Concrete or brick walls require special fasteners and anchors.
2. The wall bracket has holes spaced at 16" and 24" to align with most wall studs.
3. The bracket must be level and plumb.
4. Keep in mind you will need at least 2-3/4" between the ceiling and the top of the wall mount bracket to be able to position the case on the bracket.
5. Mount the screen case on the wall bracket as shown in figure 2. Be sure the case is fully seated on the bracket. Tighten the stop screws against the wall bracket.

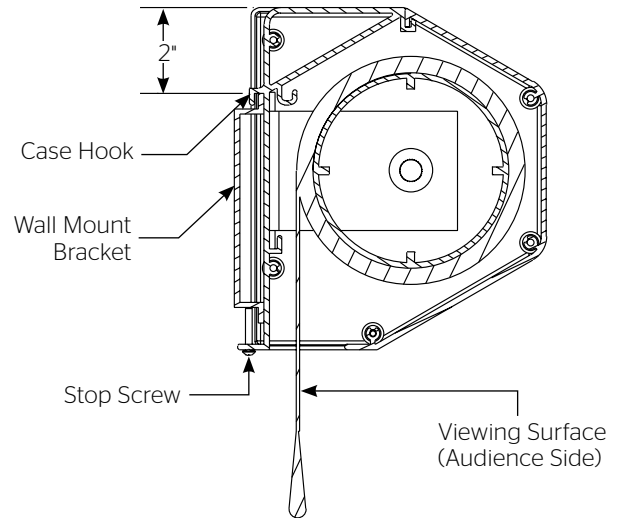

Figure 2

Ceiling Mount

1. Be sure the ceiling has adequate reinforcement to attach the screen brackets.
2. Attach the ceiling brackets to the wall mount bracket using the supplied 5/16" x 3/4" bolts, washers and nuts.
3. Position the ceiling bracket assembly on the ceiling and attach with 5/16" bolts (not supplied). The bolts should be long enough to pass through the drywall or ceiling tile and penetrate at least 1-1/2" into the reinforcement in the ceiling.
4. Mount the screen on the wall bracket as shown in figure 3. Be sure the case is fully seated on the bracket. Tighten the stop screws against the wall bracket.

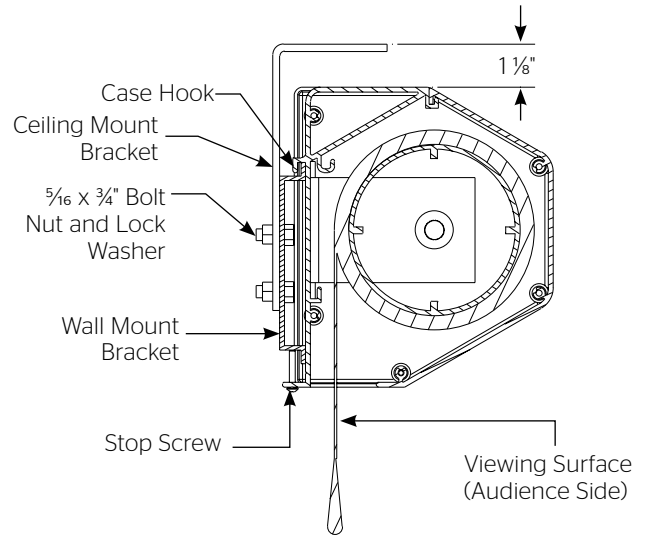

Figure 3

Installation For Screens Without A Built-In Low Voltage Control

Internal wiring has been completed at the factory. Installer must route power to the wall switch and to the junction box located on the left end of the screen case.

See wiring diagram below for wire connections.

NOTE: This screen can only be controlled by a single 120VAC or 240VAC wall switch. To use multiple switches, an optional low voltage control must be used.

120V Wiring Diagram For Standard Wall Switch

Junction Box
Located In Left Endcap

NOTE: A single switch cannot be used to operate more than one screen. Contact the factory for further information.

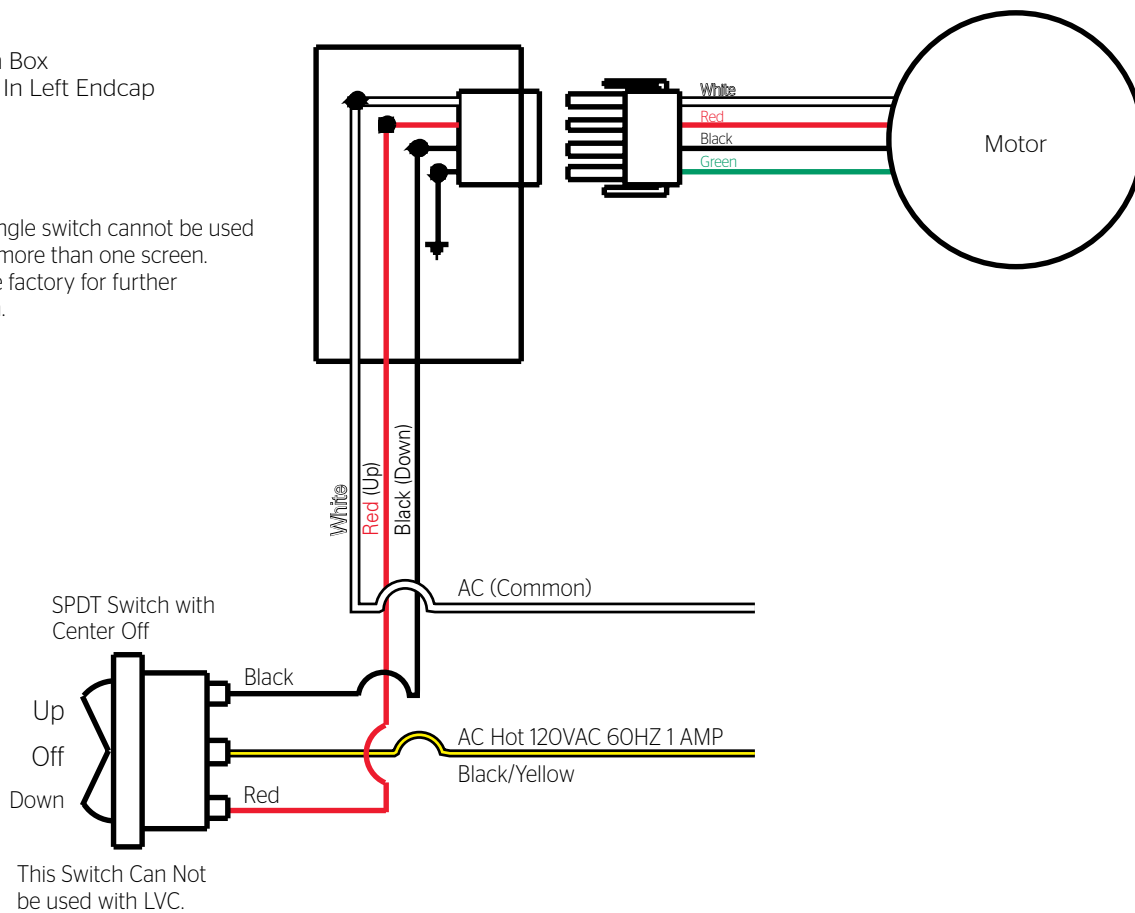

240 VOLT WIRING DIAGRAM FOR STANDARD WALL SWITCH:

Da-Lite offers two styles of 240 volt wall switches for standard operation. Please see wiring diagram in wall switch boxes included with screen.

Screen Adjustment For Screens Without A Built-In Low Voltage Control

Screen travel is stopped automatically in the down and up positions by the limit switches that are preset at the factory. No further adjustment is necessary.

If you need to make minor stop position adjustments see the appropriate step below.

SETTING THE DOWN LIMIT POSITION

NOTE: One turn of the limit screw equals approximately 2" of screen travel.

To Reduce Screen Drop: Turn the down limit switch screw clockwise to decrease the amount of screen drop. Run the screen down to test the stop position. If the screen drops too far, raise the screen about one foot and adjust the limit switch again. Repeat until the desired position is set.

To Increase Screen Drop: Turn the down limit switch screw counterclockwise to increase the amount of screen drop. Run the screen down to test the stop position. If the screen does not drop enough, raise the screen about one foot and adjust the limit switch again. Repeat until the desired position is set. Do not adjust for more drop than what was ordered. At least 1-1/2 wraps of fabric must remain on the roller.

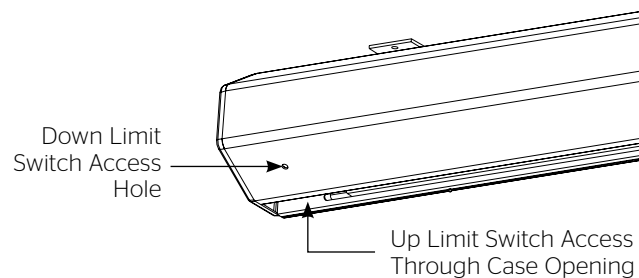

Figure 4

SETTING THE UP LIMIT POSITION

⚠ CAUTION: Do not allow the slat bar to wrap over the top of the roller when the screen is rolling into the case. The screen could be damaged.

⚠ ATTENTION: Évitez que la barre inférieure ne s'enroule au dessus du cylindre lorsque l'écran est enroulé dans le caisson. L'écran pourrait être endommagé.

Screen Travels Into Case Too Far: Turn the up limit switch screw clockwise to decrease the amount of travel. Run the screen up to test the stop position. If the screen does not stop properly, lower the screen about one foot and turn the limit switch again. Repeat until the desired position is set.

Screen Does Not Travel Far Enough Into Case: Turn the up limit switch screw counterclockwise to increase the amount of up travel. Run the screen up to test the stop position. If more travel is desired, lower the screen about one foot and adjust the limit switch again. Repeat until the desired position is set.

Installation for 120V Screens with A Built-In Low Voltage Control

120V Wiring Diagram

3-conductor 20-24 gauge wire can be used in place of the supplied RJ-14 cable to connect the wall switch. Connect the BUS terminals on the wall switch to the corresponding BUS terminals on the splitter board.

IMPORTANT NOTE: The wall switch is REQUIRED to make any limit switch adjustments, EVEN if a third party control system is used. Therefore, it is advised to wire the switch or provide a 3-conductor connection that is accessible.

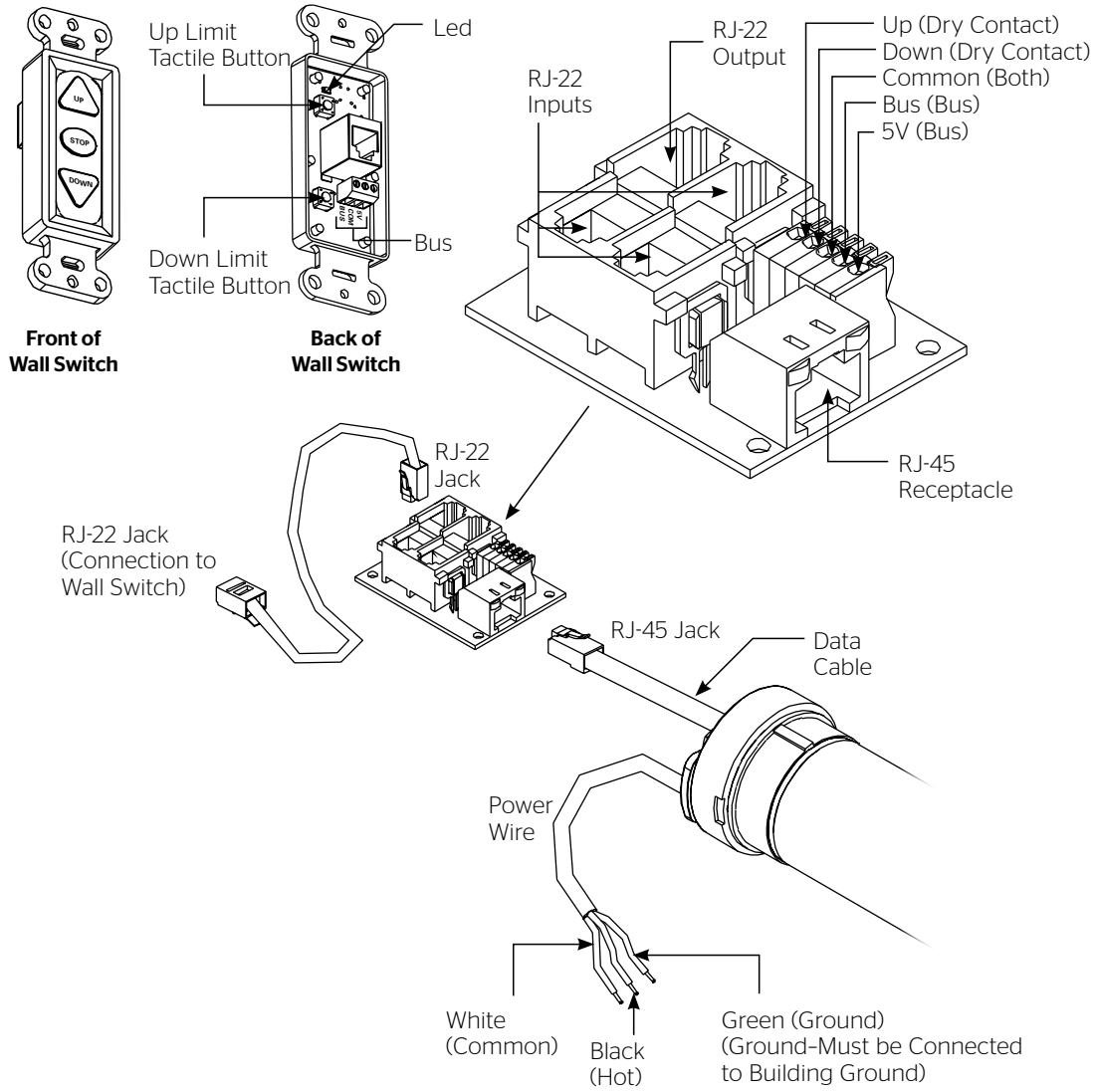

Power Input 120VAC / 60Hz

RJ-14 Pin-Outs (Tab Is Facing Up)



Supplied RJ-14 cable

RJ-22 Pin-Outs (Tab Is Facing Up)

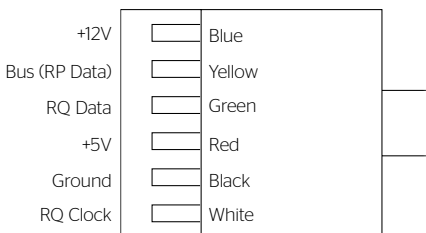

Standard RJ-22 can be used in place of RJ-14 cable

RJ-45 Pin-Outs (Tab Is Facing Up)

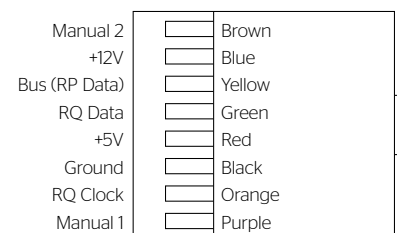

Screen Adjustment For 120V Screens With A Built-In Low Voltage Control

1. Locate the wall switch and remove the cover plate from the 3-button wall switch and remove the switch from the junction box.
2. Locate the two tactile buttons on the back of the switch. They are square silver with black round buttons. See wiring diagram.
3. To adjust the down limit switch, press and hold the down tactile button until the LED on back of switch turns solid red. This will put the motor in limit set mode. Turn the wall switch over and use the down button on front of switch. Press and hold until the desired travel position is reached. If you travel to far down you can press the up to move the screen upward. If you press and let go of either up or down button the motor will do a small jog in that direction for finer adjustment of screen. Once desired position is reached turn switch over press and hold down tactile button until the LED on back of switch blinks red twice. The down limit is now set.
4. To adjust the up limit switch, press and hold the up tactile button until the LED on back of switch turns solid green. This will put the motor in limit set mode. Turn the wall switch over and use the up button on front of switch. Press and hold until the desired travel position is reached. If you travel to far up you can press the down to move the screen downward. If you press and let go of either up or down button the motor will do a small jog in that direction for finer adjustment of screen. Once desired position is reached turn switch over press and hold up tactile button until the LED on back of switch blinks green twice. The up limit is now set.
5. To test limit switch setting, press and release the up or down button on the wall switch to operate the screen.
6. Replace switch and cover plate on the wall.

NOTE: If the screen is in limit set mode and no buttons are pushed for 20 seconds, the LED on the back of the wall switch will turn off, the motor will return to run mode and no changes will be saved. If this occurs, return to step 3 for down limit adjustment or step 4 for up limit adjustment.

IMPORTANT NOTE: The wall switch is REQUIRED to make any limit switch adjustments, EVEN if a third party control system is used. Therefore, it is advised to wire the switch or provide a 3-conductor connection that is accessible.

Installation For 240V Screens With A Built-In Low Voltage Control

240V Wiring Diagram With Optional Built-In Low Voltage Control

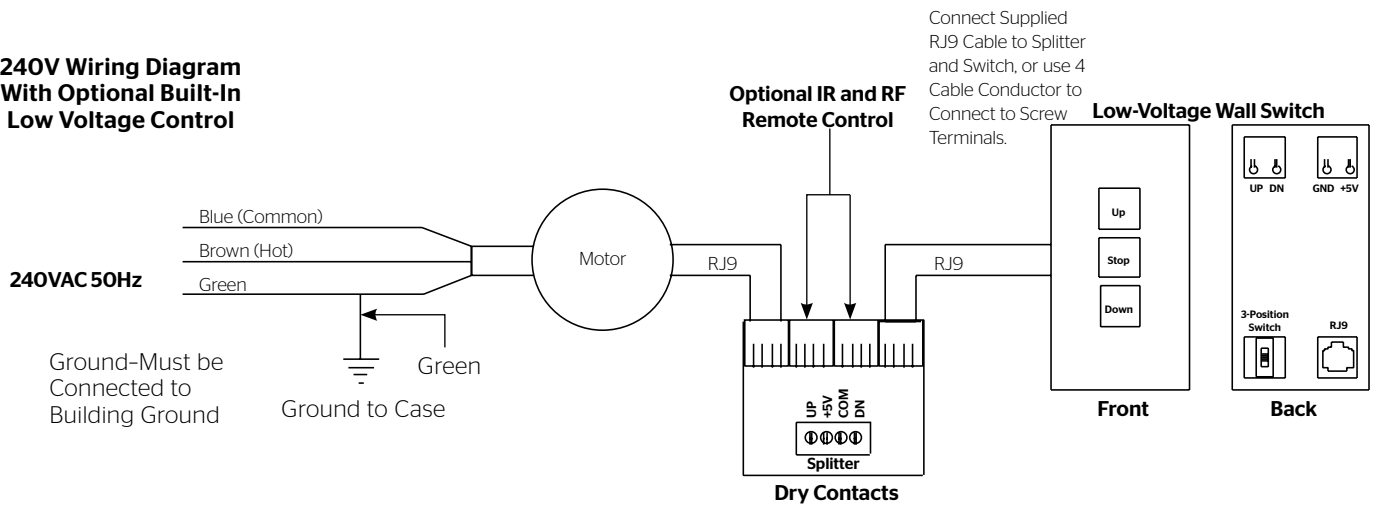

ILT RJ-9 Pin-Outs (Tab Is Facing Up)

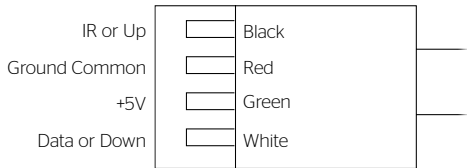

IMPORTANT NOTE: The wall switch is REQUIRED to make any limit switch adjustments, EVEN if a third party control system is used. Therefore, it is advised to wire the switch or provide a 4-conductor connection that is accessible.

Screen Adjustment For 240V Screens With A Built-In Low Voltage Control

1. Remove the cover plate from the 3-button wall switch and remove the switch from the junction box.
 2. Locate small 3-position switch on back of wall switch. See wiring diagram.
 3. To adjust the down limit switch, slide the 3-position switch to the down position. Press and hold the down button to run the screen down to the desired stop position. Release the button to stop the screen. DO NOT PUSH THE STOP BUTTON.
 4. When the screen is in the desired down position, slide the 3-position switch to the off (center) position. The down limit switch is now set.
 5. To adjust the up limit switch, slide the 3-position switch to the up position. Press and hold the up button to run the screen up to the desired stop position. Release the button to stop the screen. DO NOT PUSH THE STOP BUTTON.
 6. When the screen is in the desired up position, slide the 3-position switch to the off (center) position. The up limit switch is now set.
 7. To test limit switch setting, make sure the 3-position switch is in the off (center) position. Press and release the up or down button on the wall switch to operate the screen.
 8. Replace switch and cover plate on the wall.
- NOTE:** If stop button is pressed, the wall switch will reverse direction. To correct this, press the stop button again. This will reset the switch. You will have to re-set both the up and the down settings.
- IMPORTANT NOTE:** The wall switch is REQUIRED to make any limit switch adjustments, EVEN if a third party control system is used. Therefore, it is advised to wire the switch or provide a 4-conductor connection that is accessible.

Troubleshooting

Visit www.da-lite.com to find installation and troubleshooting videos and tutorials. You will also find a link to Live Chat for interactive support and you can contact us by email at info@da-lite.com or by phone at (800) 622-3737 or (574) 267-8101 with any troubleshooting questions.

Symptom	Cause	Solution
Screen will not operate. Motor does not hum.	Blown fuse.	Replace fuse.
	Tripped circuit breaker.	Reset circuit breaker.
	No power to operating switch or junction.	Check above. Tighten all loose wire connections. Correct any improper connections. Down Position Check for power across black and white leads. Up Position Check for power across red and white leads.
	Power at junction box Thermal overload tripped.	Let motor cool down for 15 minutes. Try again.
	Broken wire in the "down" or "up" position.	Check for continuity. Cut off old splice and reconnect.
	Defective motor, limit switch or capacitor.	Replace motor assembly. NOTE: Motor is a sealed assembly.
	Capacitor burned out.	Replace motor assembly.
Incorrect stopping position in downward direction.	Lost roller wrap.	See instructions below.
	"Down" limit switch out of adjustment.	See installation instructions.
Incorrect stopping position in upward direction.	Lost roller wrap.	See instructions below.
	"Up" limit switch out of adjustment.	Adjust "up" limit switch. Call for information.
Noise. NOTE: Screen will operate with a low pitched hum.	Gear noise.	Replace motor assembly.
Fabric rubbing.	Normal condition. NOTE: Screens with ironing boards have fabric that drags across the board.	
Coasting.	Defective brake.	Replace motor assembly.

Restoring Lost Roller Wrap

1. Tape a strap to the bottom of the screen surface.
2. Push strap over back of roller.
3. Feed fabric as you pull strap to draw fabric over top of roller.
4. Remove tape and strap.

Conditions for Transportation and Storage

- Temperature: Between 40 - 100°F (5 - 40°C)
- Relative Humidity: 30% to 70%, non-condensing
- Always keep the projection screen horizontal during transport and storage
- Make sure the entire package is supported when stored
- Do not stack more than six projection screens on top of each other
- Make sure the heaviest package is placed at the bottom of the stack

Screen surface should be allowed to air out once every two months, or otherwise used on a regular basis, if the temperature is above 72°F (22°C) and at least once every month if the temperature goes above 85°F (30°C).

LIMITED FIVE YEAR WARRANTY ON DA-LITE PRESENTATION PRODUCTS

Milestone AV Technologies LLC warrants certain Da-Lite branded products to the original purchaser only, to be free from defects in materials and workmanship for a period of five (5) years from the date of purchase by the original purchaser; provided they are properly operated according to Da-Lite's instructions and are not damaged due to improper handling or treatment after shipment from the factory.

This warranty does not apply to equipment showing evidence of misuse, abuse or accidental damage, or which has been tampered with or repaired by a person other than authorized Da-Lite personnel.

Da-Lite's sole obligation under this warranty shall be to repair or to replace (at Da-Lite's option) the defective part of the merchandise. Returns for service should be made to your Da-Lite dealer. If it is necessary for the dealer to return the screen or part to Da-Lite, transportation expenses to and from Da-Lite are payable by the purchaser and Da-Lite is not responsible for damage in shipment. To protect yourself against damage or loss in transit, insure the product and prepay all transportation expenses.

TO THE MAXIMUM EXTENT PERMITTED BY APPLICABLE LAW, THIS WARRANTY IS IN LIEU OF ALL OTHER WARRANTIES, EXPRESS OR IMPLIED, INCLUDING WARRANTIES AS TO FITNESS FOR USE AND MERCHANTABILITY. Any implied warranties of fitness for use, or merchantability, that may be mandated by statute or rule of law are limited to the five (5) year warranty period. This warranty gives you specific legal rights, and you may also have other rights, which vary from state-to-state. **TO THE MAXIMUM EXTENT PERMITTED BY APPLICABLE LAW, NO LIABILITY IS ASSUMED FOR EXPENSES OR DAMAGES RESULTING FROM INTERRUPTION IN OPERATION OF EQUIPMENT, OR FOR INCIDENTAL, DIRECT, OR CONSEQUENTIAL DAMAGES OF ANY NATURE.**

In the event that there is a defect in materials or workmanship of a Da-Lite product, you may contact our Customer Care Specialists at 3100 North Detroit Street, Warsaw, IN 46582, (574) 267-8101, (800) 622-3737.

IMPORTANT: THIS WARRANTY SHALL NOT BE VALID AND DA-LITE BRANDED PRODUCTS SHALL NOT BE BOUND BY THIS WARRANTY IF THE PRODUCT IS NOT OPERATED IN ACCORDANCE WITH THE DA-LITE WRITTEN INSTRUCTIONS.

Keep your sales receipt to prove the date of purchase and your original ownership.



FOR YOUR IMAGE | legrandav.com

USA P 866.977.3901 E info@da-lite.com
CANADA P 877.345.4329 E canadainfo@milestone.com
EMEA P +31 495 580 840 E emea.sales@milestone.com
APAC P +852 2145 4099 E asia.da-lite@milestone.com

In British Columbia, Milestone AV Technologies ULC carries on business as MAVT Milestone AV Technologies ULC.
©2018 Milestone AV Technologies. DL-0178 (Rev. 4) 7/18 Da-Lite is a registered trademark of Milestone AV Technologies. All other brand names or marks are used for identification purposes and are trademarks of their respective owners. All patents are protected under existing designations. Other patents pending.